

(h) Definitions

For the purpose of this AD:

(1) An “engine shop visit” is the induction of an engine into the shop for maintenance involving the separation of pairs of major mating engine flanges, except that the separation of engine flanges solely for the purposes of transportation without subsequent engine maintenance does not constitute an engine shop visit.

(2) A “part eligible for installation” is an HPT rotor stage 1 disk that is not listed in Figure 1 or Figure 2 to paragraph (c) of this AD or an HPT rotor stage 1 disk that has been repaired using an FAA-approved repair.

Note 1 to paragraph (h)(2): Guidance for repairing the HPT rotor stage 1 disk can be found in GE Repair Document RD # 150–1811–P1, dated March 17, 2020.

(i) Alternative Methods of Compliance (AMOCs)

(1) The Manager, ECO Branch, FAA, has the authority to approve AMOCs for this AD, if requested using the procedures found in 14 CFR 39.19. In accordance with 14 CFR 39.19, send your request to your principal inspector or local Flight Standards District Office, as appropriate. If sending information directly to the manager of the certification office, send it to the attention of the person identified in paragraph (j)(1) of this AD. Information may be emailed to: *ANE-AD-AMOC@faa.gov*.

(2) Before using any approved AMOC, notify your appropriate principal inspector, or lacking a principal inspector, the manager of the local flight standards district office/certificate holding district office.

(j) Related Information

(1) For more information about this AD, contact Scott Stevenson, Aviation Safety Engineer, ECO Branch, FAA, 1200 District Avenue, Burlington, MA 01803; phone: (781) 238–7132; fax: (781) 238–7759; email: *Scott.M.Stevenson@faa.gov*.

(2) For service information identified in this AD, contact General Electric Company, 1 Neumann Way, Cincinnati, OH 45215; phone: (513) 552–3272; email: *aviation.fleetsupport@ae.ge.com*; website: *https://www.ge.com*. You may view this referenced service information at the FAA, Airworthiness Products Section, 1200 District Avenue, Burlington, MA 01803. For information on the availability of this material at the FAA, call (781) 238–7759.

Issued on September 30, 2021.

Lance T. Gant,

Director, Compliance & Airworthiness Division, Aircraft Certification Service.

[FR Doc. 2021–21905 Filed 10–7–21; 8:45 am]

BILLING CODE 4910–13–C

DEPARTMENT OF TRANSPORTATION**Federal Aviation Administration****14 CFR Part 39**

[Docket No. FAA–2021–0872; Project Identifier MCAI–2021–00312–R]

RIN 2120–AA64

Airworthiness Directives; Airbus Helicopters

AGENCY: Federal Aviation Administration (FAA), DOT.

ACTION: Notice of proposed rulemaking (NPRM).

SUMMARY: The FAA proposes to supersede Airworthiness Directive (AD) 2020–11–05, which applies to all Airbus Helicopters Model EC120B helicopters. AD 2020–11–05 requires repetitive inspections of the tail rotor (TR) hub body for cracks and applicable corrective actions if necessary, and repetitive replacement of the attachment bolts, washers, and nuts of the TR hub body. This proposed AD would retain certain requirements of AD 2020–11–05, add repetitive inspections, require additional corrective actions, and update applicable service information. The FAA is proposing this AD to address the unsafe condition on these products.

DATES: The FAA must receive comments on this proposed AD by November 22, 2021.

ADDRESSES: You may send comments, using the procedures found in 14 CFR 11.43 and 11.45, by any of the following methods:

- *Federal eRulemaking Portal:* Go to *https://www.regulations.gov*. Follow the instructions for submitting comments.

- *Fax:* (202) 493–2251.

- *Mail:* U.S. Department of Transportation, Docket Operations, M–30, West Building Ground Floor, Room W12–140, 1200 New Jersey Avenue SE, Washington, DC 20590.

- *Hand Delivery:* Deliver to Mail address above between 9 a.m. and 5 p.m., Monday through Friday, except Federal holidays.

For service information identified in this NPRM, contact Airbus Helicopters, 2701 North Forum Drive, Grand Prairie, TX 75052; telephone (972) 641–0000 or (800) 232–0323; fax (972) 641–3775; or at *https://www.airbus.com/helicopters/services/technical-support.html*. You may view this service information at the FAA, Office of the Regional Counsel, Southwest Region, 10101 Hillwood Pkwy., Room 6N–321, Fort Worth, TX 76177. For information on the

availability of this material at the FAA, call (817) 222–5110.

Examining the AD Docket

You may examine the AD docket at *https://www.regulations.gov* by searching for and locating Docket No. FAA–2021–0872; or in person at Docket Operations between 9 a.m. and 5 p.m., Monday through Friday, except Federal holidays. The AD docket contains this NPRM, the European Union Aviation Safety Agency (EASA) AD, any comments received, and other information. The street address for Docket Operations is listed above.

FOR FURTHER INFORMATION CONTACT:

Andrea Jimenez, Aerospace Engineer, COS Program Management Section, Operational Safety Branch, Compliance & Airworthiness Division, FAA, 1600 Stewart Ave., Suite 410, Westbury, NY 11590; telephone (516) 228–7330; email *andrea.jimenez@faa.gov*.

SUPPLEMENTARY INFORMATION:**Comments Invited**

The FAA invites you to send any written relevant data, views, or arguments about this proposal. Send your comments to an address listed under **ADDRESSES**. Include “Docket No. FAA–2021–0872; Project Identifier MCAI–2021–00312–R” at the beginning of your comments. The most helpful comments reference a specific portion of the proposal, explain the reason for any recommended change, and include supporting data. The FAA will consider all comments received by the closing date and may amend this proposal because of those comments.

Except for Confidential Business Information (CBI) as described in the following paragraph, and other information as described in 14 CFR 11.35, the FAA will post all comments received, without change, to *https://www.regulations.gov*, including any personal information you provide. The agency will also post a report summarizing each substantive verbal contact received about this NPRM.

Confidential Business Information

CBI is commercial or financial information that is both customarily and actually treated as private by its owner. Under the Freedom of Information Act (FOIA) (5 U.S.C. 552), CBI is exempt from public disclosure. If your comments responsive to this NPRM contain commercial or financial information that is customarily treated as private, that you actually treat as private, and that is relevant or responsive to this NPRM, it is important that you clearly designate the submitted comments as CBI. Please mark each

page of your submission containing CBI as "PROPIN." The FAA will treat such marked submissions as confidential under the FOIA, and they will not be placed in the public docket of this NPRM. Submissions containing CBI should be sent to Andrea Jimenez, Aerospace Engineer, COS Program Management Section, Operational Safety Branch, Compliance & Airworthiness Division, FAA, 1600 Stewart Ave., Suite 410, Westbury, NY 11590; telephone (516) 228-7330; email andrea.jimenez@faa.gov. Any commentary that the FAA receives which is not specifically designated as CBI will be placed in the public docket for this rulemaking.

Background

The FAA issued AD 2020-11-05, Amendment 39-21130 (85 FR 31042, May 22, 2020) (AD 2020-11-05), for Airbus Helicopters Model EC120B helicopters, all serial numbers. AD 2020-11-05 requires repetitive inspections of the TR hub body for cracks and applicable corrective actions if necessary, and repetitive replacement of the attachment bolts, washers, and nuts of the TR hub body. AD 2020-11-05 was prompted by EASA AD 2019-0272R1, dated November 18, 2019 (EASA AD 2019-0272R1), issued by EASA, which is the Technical Agent for the Member States of the European Union, to correct an unsafe condition for Airbus Helicopters, formerly Eurocopter, Eurocopter France, Model EC120 B helicopters. EASA advised that an inspection of the TR hub body revealed a recurring loss of tightening torque on several attachment bolts. This condition, if not addressed, could result in cracking and potential loss of the TR drive and consequent loss of yaw control of the helicopter.

Accordingly, EASA AD 2019-0272R1 required repetitive inspections of the TR hub body for cracks and applicable corrective actions if necessary, as well as repetitive replacement of the associated attachment bolts, washers, and nuts.

Actions Since AD 2020-11-05 Was Issued

Since the FAA issued AD 2020-11-05, EASA issued AD 2021-0069, dated March 11, 2021 (EASA AD 2021-0069), which supersedes EASA AD 2019-0272R1. EASA advises that further detailed analysis showed that a loss of tightening torque in the interface between the TR hub body and splined flange creates the risk of crack initiation from a fretting area located on the TR hub body and splined flange or on the TR hub body and flange bolts.

Accordingly, EASA AD 2021-0069 retains the requirements of EASA AD 2019-0272R1 and requires additional repetitive detailed inspections of the interface between the TR hub body part number (P/N) C642A0100103 and the splined flange. Depending on the inspection results, EASA AD 2021-0069 requires accomplishment of applicable corrective actions.

FAA's Determination

These helicopters have been approved by EASA and are approved for operation in the United States. Pursuant to the FAA's bilateral agreement with the European Union, EASA has notified the FAA about the unsafe condition described in its AD. The FAA is proposing this AD after evaluating all known relevant information and determining that the unsafe condition described previously is likely to exist or develop on other helicopters of the same type designs.

Related Service Information Under 1 CFR Part 51

The FAA reviewed Airbus Helicopters Emergency Alert Service Bulletin 05A020, Revision 2, dated February 8, 2021 (ASB 05A020 Rev 2). This service information specifies procedures for repetitive inspections of the TR hub body for cracks and the TR spline flange for cracks and fretting and the appropriate corrective actions.

This service information is reasonably available because the interested parties have access to it through their normal course of business or by the means identified in the ADDRESSES section.

Proposed AD Requirements in This NPRM

This proposed AD would retain some of the requirements of AD 2020-11-05, and would require, within 15 hours time-in-service (TIS) or 7 days, whichever occurs first, performing repetitive inspections of the TR hub body for a crack and depending on the inspection results, removing the affected parts from service. This proposed AD would also require inspecting the TR spline flange for corrosion, impacts, fretting, wear, and a crack and depending on the inspection results, removing the TR splined flange from service. For helicopters with 9,000 or more total hours TIS or with unknown total hours TIS, this proposed AD would require, within 15 hours TIS or 7 days, whichever occurs first, and thereafter at intervals not to exceed 1,000 hours TIS, removing from service any bolt, washer, and nut installed on the TR hub body, replacing them with airworthy parts, inspecting the TR splined flange, and

depending on the inspection results, removing the TR splined flange from service. This proposed AD would also require, for helicopters with less than 9,000 total hours TIS, within 1,000 hours TIS or before accumulating 9,000 total hours TIS, whichever occurs first, and thereafter at intervals not to exceed 1,000 hours TIS, removing from service any bolt, washer, and nut installed on the TR hub body replacing them with airworthy parts, inspecting the TR splined flange, and depending on the inspection results, removing the TR splined flange from service. This proposed AD would also prohibit the installation of a certain part-numbered TR hub body unless certain actions have been accomplished.

Differences Between This Proposed AD and EASA AD 2021-0069

EASA AD 2021-0069 uses flight hours (FH) for certain compliance times, whereas this proposed AD uses hours TIS. EASA AD 2021-0069 retains the compliance time of November 1, 2019 for certain actions, which is the effective date of EASA AD 2019-0272R1, whereas this proposed AD would require compliance as of the effective date of the proposed AD.

Where Note 1 of EASA AD 2021-0069 allows a non-cumulative tolerance of 100 hours TIS to be applied to the compliance times for the initial replacement of bolts, washers, and nuts (Table 1 of EASA AD 2021-0069) to allow for synchronization of the required inspections with other maintenance tasks, this proposed AD would not allow a non-cumulative tolerance of 100 hours TIS to be applied to the compliance times.

Costs of Compliance

The FAA estimates that this AD, if adopted as proposed, would affect 89 helicopters of U.S. Registry. Labor rates are estimated at \$85 per work-hour. Based on these numbers, the FAA estimates the following costs to comply with this proposed AD.

Visually inspecting each TR hub body for a crack would take about 0.25 work-hour for an estimated cost of \$22 per inspection and \$1,958 for the U.S. fleet.

Visually inspecting each TR spline flange for corrosion, impacts, fretting, wear, and a crack would take about 0.25 work-hour for an estimated cost of \$22 per inspection and \$1,958 for the U.S. fleet.

Replacing a TR hub body would take about 2 work-hours and parts would cost about \$16,417 for an estimated cost of \$16,587 per TR hub body replacement.

Replacing a TR spline flange would take about 0.5 work-hour and parts would cost about \$2,950 for an estimated cost of \$2,993 per TR spline flange replacement.

Replacing a bolt, washer, and nut would take about 0.5 work-hour and parts would cost about \$68 for an estimated cost of \$111 per replacement.

Authority for This Rulemaking

Title 49 of the United States Code specifies the FAA's authority to issue rules on aviation safety. Subtitle I, section 106, describes the authority of the FAA Administrator. Subtitle VII: Aviation Programs, describes in more detail the scope of the Agency's authority.

The FAA is issuing this rulemaking under the authority described in Subtitle VII, Part A, Subpart III, Section 44701: General requirements. Under that section, Congress charges the FAA with promoting safe flight of civil aircraft in air commerce by prescribing regulations for practices, methods, and procedures the Administrator finds necessary for safety in air commerce. This regulation is within the scope of that authority because it addresses an unsafe condition that is likely to exist or develop on products identified in this rulemaking action.

Regulatory Findings

The FAA determined that this proposed AD would not have federalism implications under Executive Order 13132. This proposed AD would not have a substantial direct effect on the States, on the relationship between the national Government and the States, or on the distribution of power and responsibilities among the various levels of government.

For the reasons discussed, I certify this proposed regulation:

(1) Is not a "significant regulatory action" under Executive Order 12866,

(2) Would not affect intrastate aviation in Alaska, and

(3) Would not have a significant economic impact, positive or negative, on a substantial number of small entities under the criteria of the Regulatory Flexibility Act.

List of Subjects in 14 CFR Part 39

Air transportation, Aircraft, Aviation safety, Incorporation by reference, Safety.

The Proposed Amendment

Accordingly, under the authority delegated to me by the Administrator, the FAA proposes to amend 14 CFR part 39 as follows:

PART 39—AIRWORTHINESS DIRECTIVES

■ 1. The authority citation for part 39 continues to read as follows:

Authority: 49 U.S.C. 106(g), 40113, 44701.

§ 39.13 [Amended]

- 2. The FAA amends § 39.13 by:
 - a. Removing Airworthiness Directive 2020–11–05, Amendment 39–21130 (85 FR 31042, May 22, 2020); and
 - b. Adding the following new airworthiness directive:

Airbus Helicopters: Docket No. FAA–2021–0872; Project Identifier MCAI–2021–00312–R.

(a) Comments Due Date

The FAA must receive comments on this airworthiness directive (AD) action by November 22, 2021.

(b) Affected ADs

This AD replaces AD 2020–11–05, Amendment 39–21130 (85 FR 31042, May 22, 2020) (AD 2020–11–05).

(c) Applicability

This AD applies to Airbus Helicopters Model EC120B helicopters, certificated in any category, all serial numbers.

(d) Subject

Joint Aircraft Service Component (JASC) Code: 6400, Tail rotor system.

(e) Unsafe Condition

This AD was prompted by a report of recurrent loss of tightening torque on several attachment bolts on the tail rotor (TR) hub body. The FAA is issuing this AD to detect cracking and fretting, which if not addressed, could result in potential loss of the TR drive and consequent loss of yaw control of the helicopter.

(f) Compliance

Comply with this AD within the compliance times specified, unless already done.

(g) Required Actions

(1) Within 15 hours time-in-service (TIS) or 7 days, whichever occurs first after the effective date of this AD, and thereafter at intervals not to exceed 15 hours TIS, using a light source and mirror, visually inspect TR hub body part number (P/N) C642A0100103 for a crack in the entire inspection area depicted in Figure 1 of Airbus Helicopters Emergency Alert Service Bulletin 05A020 Revision 2, dated February 8, 2021 (ASB 05A020 Rev 2). If there is a crack, before further flight, perform the actions in paragraphs (g)(1)(i) and (ii) of this AD.

(i) Remove the TR hub body and each bolt, washer, and nut installed on the TR hub body from service and replace with airworthy parts.

(ii) Inspect the TR splined flange for corrosion, impacts, fretting, wear, and a crack in the areas identified in Figure 2 of this AD. If the condition of the part (including corrosion, impacts, fretting, wear, or cracks) exceeds the criteria as specified in Figure 1 of this AD, before further flight, remove the splined flange from service and replace with an airworthy part.

Note 1 to paragraph (g)(1)(ii): You may refer to "Detailed Check—Splined Flange," Task 64–21–00, 6–5, Airbus Aircraft Maintenance Manual (AMM), dated October 15, 2020 which pertains to the TR splined flange inspection.

BILLING CODE 4910–13–P

Figure 1 to paragraph (g)(1)(ii) – Inspection Criteria for Tail Rotor Splined*Flange*

Location as specified in figure 2 to paragraph (g)(1)(ii) of this AD	Maximum damage, which causes replacement (E1, Dia. 2, Dia. 3, and Dia. 4 are shown in figure 2 to paragraph (g)(1)(ii) of this AD)
Zone A	Scratch depth > 0.2 mm (0.008 in.). Crack. E1 < 2.75 mm (0.108 in.). Dia. 3 > 6.02 mm (0.2371 in.). Dia. 2 > 33.03 mm (1.3004 in.).
Zone B	Touch-up depth > 0.1 mm (0.004 in.). Crack.
Zone C	Crack. Scratch depth > 0.2 mm (0.008 in.).
Zone D [Dia. 4 = 14 mm +/- 0.1 mm (0.548; 0.555in.)]	Touch-up depth > 0.1 mm (0.004 in.). Crack. E1 < 2.75 mm (0.108 in.).

Figure 2 to paragraph (g)(1)(ii) – Inspection Areas of Tail Rotor Splined Flange

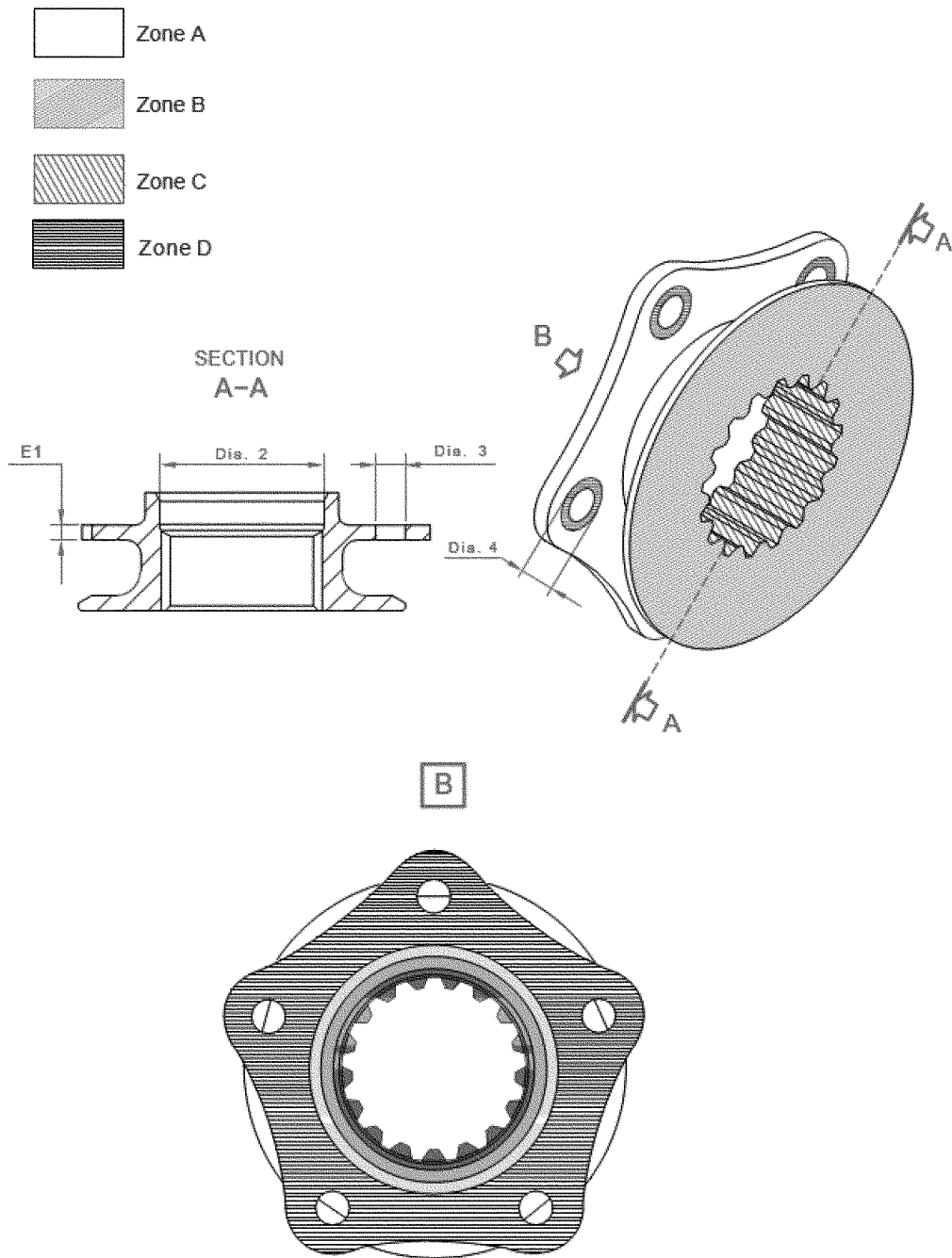

BILLING CODE 4910-13-C

(2) For helicopters with 9,000 or more total hours TIS, or with unknown total hours TIS, within 15 hours TIS or 7 days, whichever occurs first after the effective date of this AD, and thereafter at intervals not to exceed 1,000 hours TIS, remove each bolt, washer, and nut installed on the TR hub body from service and replace with airworthy parts and perform the actions in paragraph (g)(1)(ii) of this AD.

(3) For helicopters with less than 9,000 total hours TIS, within 1,000 hours TIS or before accumulating 9,000 total hours TIS, whichever occurs first after the effective date of this AD, and thereafter at intervals not to

exceed 1,000 hours TIS, remove each bolt, washer, and nut installed on the TR hub body from service and replace with airworthy parts and perform the actions in paragraph (g)(1)(ii) of this AD.

(4) As of the effective date of this AD, do not install TR hub body P/N C642A0100103 on any helicopter, unless the actions of paragraph (g)(1) of this AD have been accomplished.

(h) Special Flight Permits

A special flight permit may be permitted provided that there are no passengers onboard.

(i) Alternative Methods of Compliance (AMOCs)

(1) The Manager, International Validation Branch, FAA, has the authority to approve AMOCs for this AD, if requested using the procedures found in 14 CFR 39.19. In accordance with 14 CFR 39.19, send your request to your principal inspector or local Flight Standards District Office, as appropriate. If sending information directly to the manager of the International Validation Branch, send it to the attention of the person identified in paragraph (j)(1) of this AD.

Information may be emailed to: 9-AVS-AIR-730-AMOC@faa.gov.

(2) Before using any approved AMOC, notify your appropriate principal inspector, or lacking a principal inspector, the manager of the local flight standards district office/certificate holding district office.

(j) Related Information

(1) For more information about this AD, contact Andrea Jimenez, Aerospace Engineer, COS Program Management Section, Operational Safety Branch, Compliance & Airworthiness Division, FAA, 1600 Stewart Ave., Suite 410, Westbury, NY 11590; telephone (516) 228-7330; email andrea.jimenez@faa.gov.

(2) For service information identified in this AD, contact Airbus Helicopters, 2701 North Forum Drive, Grand Prairie, TX 75052; telephone (972) 641-0000 or (800) 232-0323; fax (972) 641-3775; or at <https://www.airbus.com/helicopters/services/technical-support.html>. You may view this referenced service information at the FAA, Office of the Regional Counsel, Southwest Region, 10101 Hillwood Pkwy., Room 6N-321, Fort Worth, TX 76177. For information on the availability of this material at the FAA, call (817) 222-5110.

(3) The subject of this AD is addressed in European Union Aviation Safety Agency (EASA) AD 2021-0069, dated March 11, 2021. You may view the EASA AD on the internet at <https://www.regulations.gov> in Docket No. FAA-2021-0872.

Issued on October 1, 2021.

Lance T. Gant,

Director, Compliance & Airworthiness Division, Aircraft Certification Service.

[FR Doc. 2021-21955 Filed 10-7-21; 8:45 am]

BILLING CODE 4910-13-P

DEPARTMENT OF TRANSPORTATION

Federal Aviation Administration

14 CFR Part 39

[Docket No. FAA-2021-0842; Project Identifier 2019-CE-032-AD]

RIN 2120-AA64

Airworthiness Directives; Stemme AG Gliders

AGENCY: Federal Aviation Administration (FAA), DOT.

ACTION: Notice of proposed rulemaking (NPRM).

SUMMARY: The FAA proposes to adopt a new airworthiness directive (AD) for certain Stemme AG Model Stemme S 12 gliders. This proposed AD was prompted by mandatory continuing airworthiness information (MCAI) issued by the aviation authority of another country to identify and correct an unsafe condition on an aviation product. The MCAI describes the unsafe condition as the incorrect installation of

an axle connecting the main landing gear (MLG) to the center steel frame. This proposed AD would require inspecting the MLG installation. The FAA is proposing this AD to address the unsafe condition on these products.

DATES: The FAA must receive comments on this proposed AD by November 22, 2021.

ADDRESSES: You may send comments, using the procedures found in 14 CFR 11.43 and 11.45, by any of the following methods:

- *Federal eRulemaking Portal:* Go to <https://www.regulations.gov>. Follow the instructions for submitting comments.

- *Fax:* (202) 493-2251.

- *Mail:* U.S. Department of Transportation, Docket Operations, M-30, West Building Ground Floor, Room W12-140, 1200 New Jersey Avenue SE, Washington, DC 20590.

- *Hand Delivery:* Deliver to Mail address above between 9 a.m. and 5 p.m., Monday through Friday, except Federal holidays.

For service information identified in this NPRM, contact STEMME AG, Flugplatzstrasse F2, Nr. 6-7, D-15344 Strausberg, Germany; phone: + 49 (0) 3341 3612-0, fax: + 49 (0) 3341 3612-30; email: airworthiness@stemme.de; website: <https://www.stemme.com>. You may view this service information at the FAA, Airworthiness Products Section, Operational Safety Branch, 901 Locust, Kansas City, MO 64106. For information on the availability of this material at the FAA, call (816) 329-4148.

Examining the AD Docket

You may examine the AD docket at <https://www.regulations.gov> by searching for and locating Docket No. FAA-2021-0842; or in person at Docket Operations between 9 a.m. and 5 p.m., Monday through Friday, except Federal holidays. The AD docket contains this NPRM, the MCAI, any comments received, and other information. The street address for Docket Operations is listed above.

FOR FURTHER INFORMATION CONTACT: Jim Rutherford, Aviation Safety Engineer, General Aviation & Rotorcraft Section, International Validation Branch, FAA, 901 Locust, Room 301, Kansas City, MO 64106; phone: (816) 329-4165; fax: (816) 329-4090; email: jim.rutherford@faa.gov.

SUPPLEMENTARY INFORMATION:

Comments Invited

The FAA invites you to send any written relevant data, views, or arguments about this proposal. Send your comments to an address listed under **ADDRESSES**. Include "Docket No.

FAA-2021-0842; Project Identifier 2019-CE-032-AD" at the beginning of your comments. The most helpful comments reference a specific portion of the proposal, explain the reason for any recommended change, and include supporting data. The FAA will consider all comments received by the closing date and may amend this proposal because of those comments.

Except for Confidential Business Information (CBI) as described in the following paragraph, and other information as described in 14 CFR 11.35, the FAA will post all comments received, without change, to <https://www.regulations.gov>, including any personal information you provide. The agency will also post a report summarizing each substantive verbal contact received about this NPRM.

Confidential Business Information

CBI is commercial or financial information that is both customarily and actually treated as private by its owner. Under the Freedom of Information Act (FOIA) (5 U.S.C. 552), CBI is exempt from public disclosure. If your comments responsive to this NPRM contain commercial or financial information that is customarily treated as private, that you actually treat as private, and that is relevant or responsive to this NPRM, it is important that you clearly designate the submitted comments as CBI. Please mark each page of your submission containing CBI as "PROPIN." The FAA will treat such marked submissions as confidential under the FOIA, and they will not be placed in the public docket of this NPRM. Submissions containing CBI should be sent to Jim Rutherford, Aviation Safety Engineer, General Aviation & Rotorcraft Section, International Validation Branch, FAA, 901 Locust, Room 301, Kansas City, MO 64106. Any commentary that the FAA receives which is not specifically designated as CBI will be placed in the public docket for this rulemaking.

Background

The European Union Aviation Safety Agency (EASA), which is the Technical Agent for the Member States of the European Union, has issued EASA AD 2019-0130-E, dated June 7, 2019 (referred to after this as "the MCAI"), to address an unsafe condition on Stemme AG Model Stemme S 12 gliders. The MCAI states:

Following a production acceptance flight, the pilot noticed that the aeroplane was in a banked position on the ground. Further examination determined that an axle, connecting the main landing gear (MLG) leg to the centre steel frame of the aeroplane, had