



1 Airport Road – Hangar 1, Suite 208, Morristown NJ 07960
Office Phone: 800-270-4987
info@alphadronesusa.com
www.AlphaDronesUSA.com

March 23, 2021

U.S. Department of Transportation, Docket Operations
West Building Ground Floor, Room W12-140
1200 New Jersey Avenue, SE
Washington, DC 20590

Re: Petition for an Exemption to Conduct Unmanned Aircraft Systems (UAS) Operations Allowed by Special authority for certain unmanned aircraft systems. Title 49 U.S.C. § 44807, and 14 C.F.R. Part 11 to Authorize Commercial Agricultural- Related Services with UAS Weighing 55 Pounds or More

A. SUMMARY:

On behalf of Alpha Drones USA, an agricultural services company, and pursuant to Title 49 U.S.C. § 44807, Special authority for certain unmanned aircraft systems and 14 C.F.R. Part 11, Alpha Drones USA hereby respectfully requests expedited approval and necessary exemptions from the following listed Code of Federal Regulations (“CFR”) for the purpose of operating the DJI AGRAS T-16 unmanned aircraft system (“UAS”) weighing over 55 pounds but no more than 97.2 pounds, for vegetation control for electrical utility right of ways, pipeline and railroad right of ways, as well as row crop applications. The operations will be conducted within and under the conditions outlined herein, or as may be established by the FAA, as required by Title 49 U.S.C. § 44807.

As described more fully below in this particular petition, the requested exemption would permit the operation of the DJI AGRAS T-16 by petitioner, under controlled conditions in predetermined airspace that is, 1) Limited in scope 2) Controlled as to access by mission essential personnel only. Grant of the requested exemption is based upon the concise direction expressed within Title 49 U.S.C. § 44807; the added authority granted by the Act, as amended; an equivalent level of safety regarding flight operations as expressed herein, and significant cost savings achieved by transitioning from traditional manned aerial resources to UASs. The petitioner respectfully requests that the FAA grant the requested exemption without delay. Petitioner will operate the DJI AGRAS T-16 while keeping the documents required by the regulations at the ground control station and immediately accessible to the Pilot in Command (PIC) and by modification of the required markings (registration number) of the UAS to be displayed on the fuselage.

The name and address of the Petitioner is:

Alpha Drones USA

The primary contact for this petition, is:

Kelvin King
1 Airport Road, Hanger 1
Suite 208
Morristown, NJ

B. BACKGROUND OF PETITIONER AND MANUFACTURER

Alpha Drones USA is a diversified provider of agricultural and forestry services for a wide variety of Government and commercial clients. Alpha Drones USA will be utilizing the T-16s for the spray application of liquid herbicides, fungicides, and pesticides on agricultural crops such as corn, soybeans, wheat and rice. This will include using the T-16 for spray application of chemicals and fertilizers as well as granular products such as lime and seed in each of these areas and on each crop.

Alpha Drones USA is utilizing their experience in agriculture to expand into missions well suited for UAS/drones to reduce risk and improve efficiencies and value added. For all operations, the T-16 has a maximum flight height of no more than 100'. This allows for clearance of obstacles such as trees, buildings, power lines etc. Having said that, the primary flight height during operation will be 10' feet above the canopy of the crop being sprayed. (typically 18-25 feet elevation from the ground) Alpha Drones USA plans to provide a wide array of services in agricultural markets where UAS/drones fit the mission better and safer than manned aircraft. The major benefits to the general public are 1) reduction in injury to ground based applicators in challenging terrain, 2) reduced exposure to chemicals for applicators, 3) reduction in chemical drift compared to manned aircraft application, 4) reduced risk to flight crew compared to manned aircraft, 5) reduced exposure of surrounding beneficial vegetation, 6) more environmentally friendly application with reduced noise, 7) selective use of chemicals for a safer more targeted application, and 8) better value for the customer.

The UAS for the purposes of this petition is the DJI AGRAS T-16.

DJI has an unparalleled presence in the UAS market with steadfast commitment to R&D, a culture of constant innovation and curiosity, and a focus on transforming complex technology into easy-to-use devices. Building on the ethos of "form follows function," DJI products combine advanced technology with dynamic designs.

Established to produce DJI's innovative products safely and responsibly, the wholly owned subsidiary Shenzhen Dajiang Baiwang Technology Co., Ltd. is a high-tech manufacturing facility specializing in unmanned aerial vehicles.

In 2016, Dajiang Baiwang passed the ISO 9001:2015 Quality Management System Certification and in 2017 passed the SGS ISO 14001:2015 Environmental Management System Certification.

DJI's offices can now be found in the United States, Germany, the Netherlands, Japan, South Korea, Beijing, Shanghai, and Hong Kong. As a privately owned and operated company, DJI focuses on its vision, supporting creative, commercial, and nonprofit applications of their technology.

Today, DJI products are redefining industries. Professionals in filmmaking, agriculture, conservation, search and rescue, energy infrastructure, and more customers trust DJI to bring new perspectives to their work and help them accomplish feats safer, faster, and with greater efficiency than ever before.

To date, the AGRAS T-16 has logged 3,097,231.38 hours of testing and flight

telemetry data and has sold over 20,000 units worldwide.

C. SYSTEM BENEFITS AND PUBLIC INTEREST

1. Alpha Drones USA intent along with a complete range of vegetation and noxious weed control and management services, is to provide a wide array of services to the utility, telecommunications, oil and gas and agricultural utilizing the DJI T16 system optimized principally for spray applications.

Their processes protect crops from biological organisms, including weeds, pathogens, and arthropods, that interferes with the production of crops affecting quality and/or yield, which can impact consumers through higher crop prices. Spraying herbicides benefits agricultural ecology and increases the efficiency of harvesting operations. Further the selective use of chemicals for a safer more targeted application for utility weed control reduces the negative impact of excess pesticide application and residual chemicals being left in the soil or running off into streams or the water table.

2. Applications by manned helicopters for agriculture carries significant risks of fatality.¹ This was such a concern that in 2014 the National Transportation and Safety Board commissioned a report to understand root causes. The enhanced safety achieved using an unmanned aircraft with the specifications described in this petition, as opposed to the much larger, manned aircraft carrying fuel and crew or passengers, is safer and exposes workers and other people on the ground to significantly less risk. Additionally, Alpha Drones USA UA uses batteries which are not as flammable and explosive as 100LL or Jet A fuel. If there was an emergency where the UA crashed, there is a significantly lower chance of individuals being injured from an explosion or fire.
3. According to a USDA Economic Research Service Report, of the United States' 408 million acres of cropland, about 70% (286 million acres) is commercially treated with crop protection products. Out of that, the agricultural aviation industry treats 71 million acres of cropland aurally each year. By utilizing UAS, this vital portion of our nation's food supply can be treated in a more environmentally safe way, thus protecting our streams from excessive chemical run off, algae blooms, etc.
4. A large portion of the agricultural land is currently sprayed by crews on foot, carrying heavy loads on steep, dangerous terrain. Alpha Drones USA will replace this method using its aircraft. It is in the interest of safety to reduce worker exposure to this difficult and dangerous environment.
5. Manned aircraft availability and scheduling are becoming increasingly difficult and costly for Alpha Drones USA customers. On average, each manned aerial application business has 2.1 aircraft, ranging in price from \$100,000 to \$1,400,000 depending on hopper size, engine type and engine size. Pilot shortages, aircraft shortages, and driver shortages are increasing. Smaller owners and non-governmental organizations without several hundred thousand acres are finding it

¹ See e.g., NTSB Special Investigative Report on the Safety of Agricultural Aircraft Operations, NTSB/SIR-14/01 (Adopted May 7, 2014):

"78 accidents [and 10 fatalities] occurred during calendar year 2013 and involved some aspect of agricultural (ag) operations, pilot training, or other crop protection activities. The report identifies the following recurring safety issues: lack of ag operations-specific fatigue management guidance, lack of ag operations-specific risk management guidance, inadequate aircraft maintenance, and lack of guidance for pilot knowledge and skills tests."

difficult to obtain economical services with these figures. Alpha Drones USA can increase service providers at a lower cost and alleviate pilot and service shortages for small landowners.

6. Manned airplanes and helicopters produce significant noise pollution that disrupt the public's ability to enjoy both private and public property. UAS are much quieter and will not disrupt the public as much as manned aircraft; thus, the benefit will be recognized as a reduction in noise pollution.
7. Pesticides being sprayed from high elevations can be picked up by the wind and carried for miles. By flying at a lower altitude (6-12 m), and by never leaving the customer's site, there is a significantly reduced chance of pesticides ("driftable fines") being accidentally sprayed in the wrong area. With manned aircraft and helicopters, this can happen in a number of ways: Pilot error or map misinterpretation en route to the site, pesticides being picked up by the wind and blown onto neighboring property affecting commercial cropland and residential areas, and equipment malfunction.

D. DESCRIPTION OF THE AGRAS T-16 UAS

The AGRAS T16 has an improved overall structure with modular design and supports the highest payload and widest spray width ever in a DJI agricultural drone. With powerful hardware, an AI engine, and 3D-operation planning, the T16 brings operation efficiency to a whole new level.

Ease of use and construction - The all-new modular design of the T16 simplifies assembly and accelerates daily maintenance. An IP67 rating provides reliable protection for key components of the drone. A light, yet durable airframe is made of carbon fiber composites and can be quickly folded to 25% of its original size, making it easy for transportation. Both the battery and spray tank are easily swappable, significantly improving the efficiency of power and liquid supply.

Spraying Efficiency - Supported by its outstanding flight performance, the T16 spray tank can carry up to 16 L, and the spray width has increased to 6.5 m. The spraying system has 4 delivery pumps and 8 sprinklers with a maximum spray rate of 4.8 L/min. The T16 can spray 24.7 acres (10 hectares) [1] per hour. The spraying system also has an all-new electromagnetic flow meter, providing higher precision and stability than conventional flow meters.

Signal Redundancies - The all-new modular aerial-electronics system in the T16 has dual IMUs and barometers and adopts a propulsion signal redundancy design to ensure flight safety. The GNSS+RTK dual-redundancy system supports centimeter-level positioning. It also supports dual-antenna technology that provides strong resistance against magnetic interference.

Onboard Radar - The T16's upgraded radar system can sense the operating environment during the **day or at night**, without being affected by light or dust. It has greatly improved flight safety with forward and backward obstacle avoidance and a horizontal FOV (field of view) of 100°, double that of previous DJI agricultural drones. It can also detect the angle of a slope and adjust to it automatically even in mountainous terrain. This innovative radar system adopts Digital Beam Forming (DBF) technology, which supports 3D point cloud imaging that effectively senses the environment and helps to circumvent obstacles.

Multiple Aircraft Capability - Numerous companies are currently operating the AGRAS T-16 throughout the United States due to its flexibility and efficiency. The T16 provides different modes for flat ground, mountains, and orchards, to meet most operational needs. Up to five T16 aircraft can be controlled by a single T16 remote

controller simultaneously, doubling the efficiency of Alpha Drones USA planned single-pilot operation of no more than two (2) aircraft.

Specifications:

Airframe	
Max Diagonal Wheelbase	1883 mm
Dimensions	2509×2213×732 mm (Arms and propellers unfolded) 1795×1510×732 mm (Arms unfolded and propellers folded) 1100×570×732 mm (Arms and propellers folded)
Propulsion System	
Motor	
Stator Size	100×15 mm
KV	75 rpm/V
Max Thrust	13.5 kg/rotor
Max Power	2400 W/rotor
Weight	616 g
Spraying System	
Spray Tank	
Volume	Rated: 15.1 L, Full: 16 L
Operating Payload	Rated: 15.1 kg, Full: 16 kg
Nozzles	
Model	XR11001VS (Standard), XR110015VS (Optional, purchase separately)
Quantity	8
Max Spray Rate	XR11001VS: 3.6 L/min, XR110015VS: 4.8 L/min
Spray Width	4-6.5 m (8 nozzles, at a height of 1.5 - 3 m above crops)
Droplet Size	XR11001VS: 130 - 250 µm, XR110015VS: 170 - 265 µm (Subject to operating environment and spray rate)
Total Weight (Excluding battery)	19.8 kg
Standard Takeoff Weight	41 kg
Max Takeoff Weight	42 kg (At sea level)
Max Thrust-Weight Ratio	1.975 (Takeoff weight of 41 kg)
Battery	DJI-approved battery pack (AB2-17500mAh-51.8V)

2600W 4 Channel Intelligent Battery Charger

Up to four batteries can be charged simultaneously. When using the single-channel quick charging mode, a full charge only takes 20 minutes, a 50% increase in speed from the previous generation. The charger has a built-in battery health management system that monitors critical data in real time, such as voltage and temperature, to ensure charging safety.

T-16 Intelligent Flight Battery

The T16 Intelligent Flight Battery has a capacity of 17,500 mAh and a 14S high voltage system that reduces power consumption. It is designed with an IP54-rated all-metal housing, and heat dissipation efficiency has increased by 140% from the previous generation. Supported by cell-balancing technology, the battery has an increased charging cycle of up to 400, 100% higher than the previous generation, significantly reducing operating costs.

E. Standard Components and Safety Systems

The T16 has an aerial-electronics system with a multiple redundancy design, and also has onboard D-RTK antennas, supporting dual-antenna technology that provides strong resistance against

magnetic interference to ensure flight safety. Thanks to the dedicated DJI industrial flight control system, the T16 offers four operation modes: Route, A-B Route, Manual, and Manual Plus. DJI MG2 automatically produces flight routes based on your planned fields. To start, simply select the field from the field list. Plan a field by walking with the remote controller, an RTK handheld mapping device, or by flying the aircraft to waypoints, according to the application scenarios. In scenarios with complicated terrain, use the PHANTOMTM 4 RTK and DJI Terra to plan 3D flight routes, and import the routes to DJI MG2 for operation.

In A-B Route operation mode, the aircraft travels along a planned route and sprays its liquid payload. Users can set the line spacing, flying speed, and other parameters.

In Manual operation mode, users can start and stop spraying manually, and also adjust the spray rate.

In Manual Plus operation mode, the flight speed is restricted, and the heading is locked. Except for the heading, users can control the movement of the aircraft via the control sticks.

Press button C1 or C2 on the remote controller or the corresponding button in the app and the aircraft will fly one line spacing to the left or right. Note that this is the default function for button C1 and button C2. They are customizable in the app.

The T16 also includes the Operation Resumption function. When pausing the operation in Route or A B Route operation mode, Operation Resumption records a breakpoint for the aircraft. Users can resume from the breakpoint when continuing the operation.

The remote controller features Multi-Aircraft Control mode, which can be used to coordinate the operation of up to five aircraft simultaneously. Turn the aircraft control switch dial on the remote controller to switch control between different aircraft.

The DBF imaging radar works automatically in Route, A-B Route, and Manual Plus operation modes during both day and night, without being affected by light or dust.

Altitude detection and stabilization functions are available in forward, backward, and downward directions while Obstacle Avoidance is available in forward or backward direction according to the direction of flight.

The radar module can detect the angle of a slope and automatically adjust to maintain the same distance with the surface even in mountainous terrain. In Route and A-B Route operation modes, the radar can effectively sense obstacles and plan a flight route to actively circumvent obstacles. Note that this is disabled by default. Users can enable it in the app.

The upgraded spraying system includes eight sprinklers placed on both sides of the aircraft to provide evenly distributed spraying and coverage of the liquid payload, and an all-new electromagnetic flow meter for higher precision and stability than conventional flow meters.

The T16 uses a dedicated DJI industrial flight controller to provide multiple operation modes for various applications. The DBF imaging radar provides terrain following to guide the aircraft to maintain a constant distance above crops in specific operation modes and is capable to actively circumvent obstacles through Auto Bypass. Functions such as operation resumption, system data protection, empty tank warning, low battery level warning, and RTH are also available.

F. Flight Modes

P-mode (Positioning): The aircraft utilizes GNSS or the RTK module for positioning. When the GNSS signal is strong, the aircraft uses GNSS for positioning. When the RTK module is enabled and the differential data transmission is strong, it provides centimeter-level positioning. The aircraft reverts to A-mode when the GNSS signal is weak. The aircraft will fly in P-mode by default.

A-mode (Attitude): GNSS is not used for positioning and the aircraft can only maintain altitude using the barometer. The aircraft enters A-mode only when there is weak GNSS signal or when the compass experiences interference. The flight speed in A-mode depends on its surroundings such as the wind speed. In A-mode, the aircraft cannot position itself and is easily affected by its surroundings, which may result in horizontal shifting. Use the remote controller to position the aircraft. Maneuvering

the aircraft in A-mode can be difficult. Avoid flying in confined spaces or in areas where the GNSS signal is weak. Otherwise, the aircraft will enter A-mode, leading to potential flight risks. Land the aircraft in a safe place as soon as possible.

G. System Data Protection

In Route or Route A-B operation mode, the System Data Protection feature enables the aircraft to retain vital system data such as operation progress and breakpoints after the aircraft is powered off to replace a battery or refill the spray tank. Follow the instructions in Operation Resumption to resume the operation after restarting the aircraft.

During Route operations, in situations such as when the app crashes or the remote controller disconnects from the aircraft, the breakpoint will be recorded by the flight controller and can be recovered in the app once the aircraft is reconnected. Go to Operation View, select, then Advanced Settings, and tap Continue Unfinished Task. Recall the operation in Executing tag in operation list.

H. Obstacle Avoidance

Obstacle avoidance is used in the following two scenarios:

1. The aircraft begins to decelerate when it detects an obstacle is 15 m away and hovers in place when 2.5 m away from the obstacle. Users can not accelerate in the direction of the obstacle but can fly in a direction away from the obstacle.
2. The aircraft immediately brakes and hovers if it detects an obstacle nearby. Users cannot control the aircraft when it is braking.

When the aircraft is hovering, it is in Obstacle Avoidance mode. Users can fly in a direction away from the obstacle to exit Obstacle Avoidance mode and regain full control of the aircraft.

I. Return to Home (RTH)

There are two types of RTH: Smart RTH and Failsafe RTH.

Smart RTH

Press and hold the RTH button on the remote controller when GNSS is available to enable Smart RTH. Both Smart and Failsafe RTH use the same procedure. With Smart RTH, you may control the speed and altitude of the aircraft to avoid collisions when returning to the home point. The aircraft status indicators will show the current flight mode during RTH. Press the RTH button once or toggle the pause switch to exit Smart RTH and regain control of the aircraft.

Failsafe RTH

Failsafe RTH is automatically activated if the remote controller signal is lost for more than three seconds, provided that the home point has been successfully recorded, the GNSS signal is strong (the white GNSS icon), and the RTK module is able to measure the heading of the aircraft. The RTH continues if the remote controller signal is recovered, and users can control the aircraft using the remote controller.

Press the RTH button once or toggle the pause switch to cancel RTH and regain control of the aircraft.

There are two ways to set a home point:

1. Set the current coordinates of the aircraft as the home point.
2. Set the current coordinates of the remote controller as the home point.

Obstacle Avoidance During RTH

In an optimal operating environment, obstacle avoidance during RTH is available. If there is an obstacle within 20 m of the aircraft, the aircraft decelerates and then stops and hovers. If the aircraft comes within 6 m of the obstacle while decelerating, the aircraft stops, flies backward to a distance of approximately 6m from the obstacle, and hovers. The aircraft exits the RTH procedure and waits for further commands.

Landing Protection Function

Landing Protection activates during auto landing.

J. DBF Imaging Radar

The all-new DBF imaging radar works during both day and night, without being affected by light or dust. In an optimal operating environment, the radar module can predict the distance between the aircraft and the vegetation or other surfaces in forward, rear, and downward directions to fly at a constant distance to ensure even spraying and terrain following capability. The DBF imaging radar can also detect obstacles 30 m away from the aircraft. The radar module adopts digital beam forming technology, which supports 3D point cloud imaging that effectively senses the environment and helps to circumvent obstacles in both Route and A-B Route operation modes. In addition, radar module limits the descent speed of the aircraft according to the distance between the aircraft and ground, to provide a smooth landing.

The altitude stabilization and obstacle avoidance functions of the radar module are enabled by default, and can be disabled in the app. When enabled, the aircraft flies above the vegetation at a constant spraying distance in Route, A-B Route, and Manual Plus operation modes. In Manual operation mode, the radar module can also measure the spraying distance above the vegetation or other surfaces, but the aircraft is not be able to fly at a constant spraying distance. The obstacle avoidance function can be used in any mode. Auto Bypass is disabled by default.

The horizontal detection range is $\pm 50^\circ$ and the vertical detection range is 0° to 10° , as shown below.

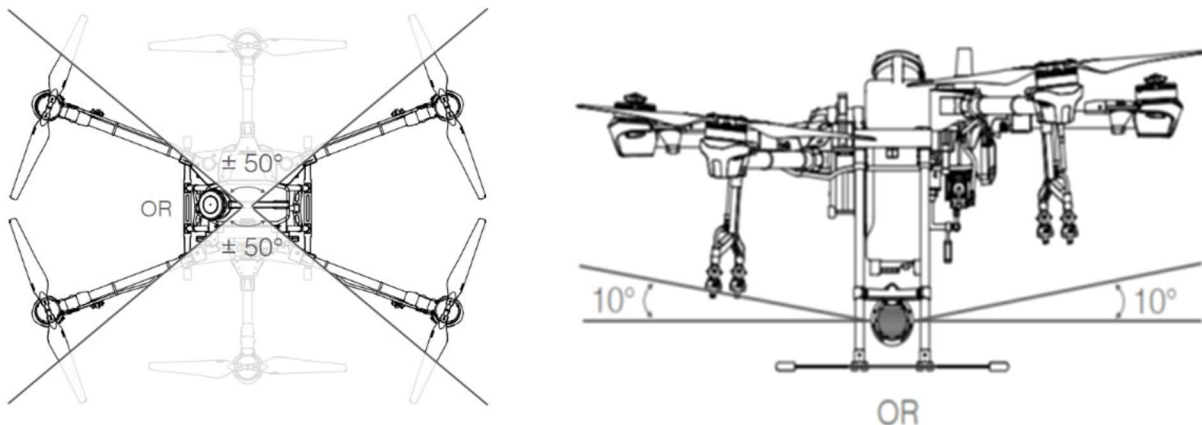

K. Low Voltage and Battery Warnings

The aircraft features a low battery warning, critical low battery warning, and critical low voltage warning.

1. Low Battery Warning: The aircraft status indicators slowly blink red. Fly the aircraft to a safe area and land it as soon as possible, stop the motors, and replace the batteries.
2. Critical Battery Warning or Critical Voltage Warning (the battery voltage is lower than 47.6 V): the aircraft status indicators rapidly blink red. The aircraft begins to descend and land automatically.

L. Flight Limits and Geofencing Zones

For safety reasons, flight limits are enabled by default to help users operate this aircraft safely and legally. Users can set flight limits on height and distance.

When operating with a strong GNSS signal, the height and distance limits and GEO Zones work together to monitor flight. With a weak GNSS signal, only the height limit prevents the aircraft from going above 30 meters.

GEO Zones are divided into different categories. All GEO Zones are listed on the DJI official website at <http://www.dji.com/flysafe>.

Flight Recording of all flights: Flight data shows a real-time video of all operator control input, GPS statuses, vibrate, shake and motor balance statuses along with battery voltage and all other critical telemetry data allowing operator to fully track entire history. All flights are automatically saved on the GCS. This further adds to safety for operator and VO training as operator-caused issues can be quickly identified.

High Visibility LED Aviation Lighting: The AGRAS T-16 has Long-range visible, high intensity LED strobes.

M. REGULATORY BASIS FOR PETITION AND REGULATIONS FROM WHICH EXEMPTION IS SOUGHT

1. 49 U.S.C § 44807

The Special Authority for Certain Unmanned Systems (49 U.S.C. § 44807) grants the Secretary of Transportation the authority to use a risk-based approach to determine whether an airworthiness certificate is required for a drone to operate safely in the NAS. Under this authority, the Secretary may grant exemptions to the applicable operating rules, aircraft requirements, and pilot requirements for a specific operation on a case-by-case basis. The Special Authority for Certain Unmanned Systems (49 U.S.C. § 44807) grants UAS operators safe and legal entry into the NAS upon consideration of its size, weight, speed, operational capability, proximity to airports and populated areas, and operation within visual line of sight. The FAA further may find that the UAS does not require “airworthiness certification under section 44704 of title 49, United States Code.”

2. 49 U.S.C. § 44701

The FAA is further authorized to grant exemptions from its safety regulations and minimum standards under 49 U.S.C. § 44701 (“Section 44701”) “if the Administrator finds the exemption is in the public interest.” Section 44701(f) (authorizing the grant of exemptions from safety regulations and minimum standards under Section 44701(a) and (b) and Sections 44702-44716). Under 49 U.S.C. § 44701(f), the “Administrator may grant an exemption from a requirement of a regulation prescribed under subsection (a) or (b) of this section or any of sections 44702-44716 of [Title 49] if the Administrator finds the exemption is in the public interest.”

For the reasons addressed herein, this Petition qualifies for expedited approval of Petitioner’s request for exemption under both 49 U.S.C § 44807 and 49 U.S.C § 44701.

Alpha Drones USA seeks exemption from the following interrelated provisions of 14 C.F.R. Parts 61, 91, and 137:

FAR	Description
§ 61.3 (a)(1)(i)	Requirement for certificates, ratings, and authorizations.
§ 91.7(a)	Civil aircraft airworthiness.
§ 91.119(c)	Minimum safe altitudes: General.
§ 91.121	Altimeter settings.
§ 91.151(b)	Fuel requirements for flight in VFR conditions.
§ 91.405(a)	Maintenance required.

§ 91.407(a)(1)	Operation after maintenance, preventive maintenance, rebuilding, and inspections.
§ 91.409(a)(1) and (2)	Inspections.
§ 91.417(a) and (b)	Maintenance records.
§ 137.19 (c), (d) and (e)(2)(ii)(iii) and (v)	Certification requirements.
§ 137.31	Aircraft requirements.
§ 137.33	Carrying of certificate.
§ 137.41(c)	Personnel, Pilot in command.
§ 137.42	Fastening of safety belts and shoulder Harnesses

Listed below are the specific Code of Federal Regulation (“CFR”) sections from which an exemption is sought, the rationale for why an exemption is needed, and a brief summary of the operating procedures and safeguards, which are described more fully in the operating documents being submitted under separate cover, which will ensure that the proposed operations can be conducted at a level of safety that is at least equal to that provided by the rule from which exemption is sought. For ease of review, this section divides the FARs from which exemption is sought into four main categories: (1) FARs pertaining to the UAS; (2) FARs pertaining to UAS Operating Parameters, and; (3) FARs pertaining to Part 137 Operating Parameters.

I. FARs Pertaining to the Unmanned Aircraft System

§ 91.405(a) *Maintenance required*

§ 91.407(a)(1) *Operation after maintenance, preventive maintenance, rebuilding, or alteration*

§ 91.409(a)(1) and (2) *Inspections*

§ 91.417(a) and (b) *Maintenance records*

Alpha Drones USA seeks an exemption from the following maintenance and inspection related FARs: §§ 91.405(a) *Maintenance required*, 91.407(a)(1) *Operation after maintenance, preventive maintenance, rebuilding, or alteration*, 91.409(a)(1) and (2) *Inspections*, and 91.417(a) and (b) *Maintenance records*. These regulations specify maintenance, inspection, and records standards in reference to FAR § 43.6. An exemption from these regulations is needed because Part 43 and these sections only apply to aircraft with an airworthiness certificate, which the UAS to be operated under this exemption will not have, and because compliance with these regulatory provisions in the context of UAS operations is not feasible.

An equivalent level of safety will be achieved because maintenance, inspections, and records handling will be performed in accordance with the manufacturer’s manual, any required manufacturer safety or service bulletins. Moreover, the PIC will conduct a pre-flight inspection of the UAS and all associated equipment to account for all discrepancies and/or inoperable components. Maintenance will be performed and verified to address any conditions potentially affecting the safe operation of the UAS, and no flights will occur unless and until all flight critical components of the UAS have been found to be airworthy and in a condition for safe operation. A functional test flight will also be conducted in a controlled environment following the replacement of any flight critical components, and, as required by

the operating documents, the PIC who conducts the functional test flight will make an entry in the UAS aircraft records of the flight. Functional flight tests will not involve the carriage of hazardous materials. In addition, the operator will be required to follow the UAS manufacturer's maintenance, overhaul, replacement, inspection, and life limit requirements for the UAS and its components. Along with the preflight checklists, Alpha Drones USA Pilot Training Program, and a routine maintenance program, Alpha Drones USA believes an equivalent level of safety is met, and that equipment at risk of failure can be safely identified before flights occur.

In the Branch Enterprises Exemption, the FAA determined that the proposed UAS operations required exemption from FAR §§ 91.405(a), 91.407(a)(1), 91.409(a)(1) and (2), and 91.417(a) and (b), and that the achievement of an adequate level of safety required certain conditions and limitations. Alpha Drones USA has proposed in this Petition a number of Limitations related to maintenance, inspections, and records which it believes provide a level of safety at least equivalent to that provided by FAR §§ 91.405(a), 91.407(a)(1), 91.409(a)(1) and (2), and 91.417(a) and (b). For this reason, and consistent with the exemption granted from these sections in the Branch Enterprises Exemption, Alpha Drones USA requests an exemption from these sections subject to the Branch Enterprises limitations, without having to perform the inspections and maintenance items required by FAR §§ 91.405(a), 91.407(a)(1), 91.409(a)(1) and (2), and 91.417(a) and (b).

II. FARs Pertaining to Unmanned Aircraft System Operating Parameters § 91.7(a) *Civil aircraft airworthiness*

Inasmuch as there will be no airworthiness certificate issued for the UAS, Alpha Drones USA seeks an exemption from FAR § 91.7(a) *Civil aircraft airworthiness*, which requires that a civil aircraft be in an airworthy condition to be operated. While the UAS operated by Alpha Drones USA will not have an airworthiness certificate, consistent with the FAA's determination in the Branch Enterprises Exemption, the pilot may determine the UA is in an airworthy condition prior to flight. As described more fully in the operating documents, this is achieved through adherence to Alpha Drones USA routine pre-flight checklist regularly scheduled maintenance, and the enhanced pilot training requirements of the Alpha Drones USA Pilot Training Program.

§ 91.119(c) *Minimum safe altitudes*

Alpha Drones USA also seeks an exemption from FAR § 91.119(c) *Minimum safe altitudes*, to the extent necessary to allow UAS operations over *other than congested areas* at altitudes lower than those permitted by rule. The ability to operate at those altitudes is one of the key benefits of using UAS for the proposed agricultural activities. An equivalent or greater level of safety will be achieved given the size, relatively light weight, and slow speed of the UAS, as well as the controlled location where the operations will occur.

Alpha Drones USA generally will try to maintain an operating altitude of between 10-25 feet AGL during its spraying operations. That altitude is only increased when exercising caution and issuing a return-to-launch command to the UAS, which causes the UAS to ascend to an altitude of 100 feet AGL before returning home. In the extremely remote and secure environment where Alpha Drones USA operations will occur, flying at a low altitude increases the aircraft's efficiency, without posing any increased risk to people or property. Even at these low altitudes, Alpha Drones USA UAS operations will be conducted at a level of safety equal to or greater than that achieved by a larger manned aircraft performing similar activities at the altitudes required by FAR § 91.119. Moreover, an equivalent or even higher level of safety can be provided instead by, as provided herein, operating so as to de-conflict

with manned vehicles operating above 500 feet AGL, within the VLOS of the PIC with the assistance of multiple VOs so as to ensure the safety of and de-conflict with any persons or property in the air and on the ground, including Participating and non-Participating personnel as well as the other UAS.

§ 91.121 Altimeter settings

Alpha Drones USA also requests an exemption from FAR § 91.121 *Altimeter settings*, which requires a person operating an aircraft to maintain cruising altitude or flight level by reference to an altimeter that is set to the elevation of the departure airport or barometric pressure. In the Branch Enterprises Exemption, the FAA stated that an equivalent level of safety to the requirements of FAR § 91.121 can be achieved in circumstances where the PIC uses an alternative means for measuring and reporting UA altitude, such as global positioning system (GPS). The UAS that Alpha Drones USA intends to use for performing the proposed operations will be equipped with GPS or other equipment for measuring and reporting UAS altitude, and the PIC will check the UA altitude reading prior to each takeoff, effectively zeroing the UA's altitude at that point. Consistent with previously granted exemptions, these requirements ensure that an equivalent level of safety will be achieved, and an exemption from the requirements of FAR § 91.121 is therefore appropriate.

§ 91.151(b), Fuel requirements for flight in VFR conditions

Finally, Alpha Drones USA seeks an exemption from FAR § 91.151(b) *Fuel requirements for flight in VFR conditions*, which would otherwise require a 20-minute fuel reserve to be maintained. The FAA has previously determined that a requirement prohibiting the PIC from beginning a UAS flight unless (considering wind and forecast weather conditions) there was enough available power for UAS to operate for the intended operational time and to operate after that with the reserve power recommended by the manufacturer which would ensure an equivalent level of safety to the fuel requirements of FAR § 91.151. Alpha Drones USA will adhere to the same reserve power requirement and an exemption from FAR § 91.151's fuel requirements for flight in VFR conditions is therefore appropriate.

III. FARs Pertaining to Part 137 Certification Requirements

Alpha Drones USA seeks an exemption from the following FARs in Part 137: §§ 137.19(c), (d) and (e)(2)(ii)(iii) and (v) *Certification requirements*, 137.31 *Aircraft requirements*, 137.33 *Carrying of certificate*, 137.41(c) *Personnel*, and 137.42 *Fastening of safety belts and shoulder harnesses*. An exemption from these FARs is necessary because the provisions are either not compatible with or are unnecessary in the context of the proposed UAS operations.

§ 137.19(c) Certification requirements

In the previous exemption granted to Branch Enterprises, the FAA determined that relief from § 137.19(c) was necessary to permit persons holding a remote PIC certificate with small UAS rating to act as PIC for commercial agricultural aircraft operations when utilizing a small UAS to conduct the operations. The FAA found that a commercial or airline transport certificate that § 137.19(c) requires was not a reasonable requirement for the UAS agricultural operations proposed by Branch Enterprises. The basis for the relief was that Branch Enterprises remote PICs would comply not only with the requirements of Part 107, sub part C, but also with the additional knowledge and applicable skill requirements in FAR § 137.19(e)(1) and (2)(i), (iv) and (vi). The relief was also based, in Part, on Branch Enterprise's compliance with the training requirements in its operating documents.

The proposed operations are identical to that previously approved by the FAA in Exemption No.18579. Consistent with the FAA’s prior analysis, compliance with the requirements of Part 107, subpart C, the additional knowledge and applicable skill requirements in FAR § 137.19(e)(1) and (2)(i), (iv) and (vi), and compliance with the training requirements in Alpha Drones USA operating documents, will ensure that an equivalent level of safety will be achieved.

§ 137.19(d) Certification requirements

§ 137.31 Aircraft requirements

In Exemption No. 18579, the FAA granted Branch Enterprises an exemption to §§ 137.19(d), *Certification requirements*, and 137.31(a), *Aircraft requirements*. Consistent with the FAA’s prior analysis in Exemption No. 18579, while Alpha Drones USA UAS will not have an airworthiness certificate, Alpha Drones USA will be capable of ensuring that the UAS are in a condition for safe operation based upon a thorough pre-flight inspection and compliance with the operating documents. The UAS components have a proven operational history and contain design safety features such that operations conducted under the requirements of this exemption will not adversely impact safety.

§ 137.19(e)(2)(ii), (iii), and (v) Certification requirements

Alpha Drones USA seeks an exemption from the knowledge and skill test requirements in § 137.19(e)(2)(ii), (iii), and (v) *Certification requirements*, because those requirements are not compatible or applicable to Alpha Drones USA proposed UAS operations. Consistent with the FAA’s prior analysis in Exemption No. 18579, Alpha Drones USA training and certification program described in the operating documents provides the remote PIC with the necessary skills to safely operate the UAS. For this reason, granting relief from a demonstration of the skills described in § 137.19(e)(2)(ii), (iii), and (v) will not adversely impact safety, and therefore relief is warranted. Alpha Drones USA pilots operating UAS under the exemption will still be required to demonstrate the skills listed at § 137.19(e)(2) as applicable, in accordance with the provisions of § 137.19(e), which requires such demonstration in order to obtain the agricultural aircraft operator certificate, unless otherwise exempted. Also, consistent with the FAA’s finding in Exemption No. 18579, that relief from the associated knowledge and skill test requirements of § 137.41(c) is also warranted because of the relief provided to § 137.19(e)(2)(ii), (iii), and (v), Alpha Drones USA seeks an exemption from the interrelated knowledge and skill test requirements of § 137.41(c).

§ 137.31(b) Aircraft requirements

§ 137.42 Fastening of safety belts and shoulder harnesses

Alpha Drones USA seeks an exemption from § 137.31(b) *Aircraft requirements*, and § 137.42 *Fastening of safety belts and shoulder harnesses*, which relate to the installation and use of a shoulder harness and safety belt on an aircraft. An exemption from these requirements is warranted because Alpha Drones USA UAS do not have an onboard pilot and these regulations are intended to ensure the safety of the onboard pilot during manned agricultural aircraft operations. For this reason, granting the requested relief from §§ 137.31(b) and 137.42 will not adversely impact safety.

§ 137.33(a) and (b) Carrying of certificate

Alpha Drones USA requests relief from § 137.33(a) *Carrying of certificate*, which requires that a facsimile of the agricultural aircraft operator certificate be carried on the aircraft. The FAA has previously determined that relief from §§ 91.9(b)(2) and 91.203(a) and (b) for the carriage of the aircraft flight manual and aircraft registration onboard the

aircraft is not necessary. Consistent with the FAA's prior analysis, an exemption is warranted here provided that a facsimile of the agricultural aircraft operator certificate and all certificates of registration are kept in a location accessible to the remote PIC.

Finally, given that Alpha Drones USA UAS will not have an airworthiness certificate, relief from § 137.33(b) *Carrying of certificate*, which requires the airworthiness certificate (if not carried in the aircraft) be kept available for inspection at the base of dispensing operation is conducted, is necessary. Alpha Drones USA will keep registration certificates available for inspection.

Alpha Drones USA has attempted to identify the appropriate C.F.R.s from which an exemption is needed in order to conduct the proposed operations in this Petition for Exemption. To the extent that the FAA determines that Alpha Drones USA needs an exemption from other C.F.R.s which are not addressed or explicitly named in order to conduct the proposed operations, Alpha Drones USA also seeks an exemption from those FARs for the reasons outlined above.

N. PILOT CERTIFICATION

§ 61.3 (a)(1)(i) Requirement for certificates, ratings, and authorizations.

No person may serve as a required pilot flight crew member of a civil aircraft of the United States unless that person:

(1) has in the person's physical possession or readily accessible in the aircraft when exercising the privileges of that pilot certificate or authorization –

(i) a pilot certificate issued under this part.

The petitioner will conduct the proposed operations under 14 CFR part 91, rather than under part 107. In general, part 91 is predicated on the presumption that the pilot in command conducting an operation under part 91 holds an airman certificate under part 61. As a result, the FAA has determined granting exemption from the requirement of § 61.3(a)(1)(i) to require a person holding a remote pilot in command certificate (with the appropriate training and demonstration of knowledge and skills required by this exemption) to conduct the operations to which this exemption applies will ensure clarity.

The statutory obligation for an airman certificate is codified at 49 U.S.C. § 44711(a)(2). Pilots who conduct operations under this exemption with a remote pilot in command certificate would comply with § 44711(a)(2), as the FAA described in the Operation and Certification of Small Unmanned Aircraft Systems final rule (81 FR 42064, 42088-89 (June 28, 2016)). The general requirements for all airmen include: eligibility, aeronautical knowledge and Transportation Security Administration (TSA) vetting. Given that the operation would occur only after airmen who hold a current remote pilot in command certificate have received specific training, have visited the area of operation and are fully capable of using the tools available to prepare for the operation, conduct comprehensive preflight actions, and conduct the operation only in a limited geographical area, the FAA has previously determined that a remote pilot certificate issued under 14 CFR part 107 provides the FAA sufficient assurance of the pilots' qualifications and abilities to perform the duties related to the operations authorized under this exemption. The remote pilot in command certificate confirms the petitioner's eligibility, secures TSA vetting, and ensures the PIC has the requisite aeronautical knowledge for operating the UAS within the NAS.

Remote pilots conducting operations under part 107 must complete a detailed aeronautical knowledge test, unless they already hold a certificate under 14 CFR part 61 and

meet the flight review requirements specified in § 61.56.9 As a result, all such pilots will have the requisite aeronautical knowledge that is a key component of safe completion of all operations that will occur under this exemption. In this regard, the FAA addressed the applicable parts of § 61.125, Aeronautical knowledge, in the remote pilot in command certificate requirements. _

For the reasons discussed below, this same rationale espoused by the FAA in previous approved exemptions, combined with Alpha Drones USA proposed safety mitigations, also supports a finding that the proposed operations under the requested exemptions can be conducted without adversely affecting safety.

While it is true that operations involving UAS weighing 55 pounds or more could raise additional safety concerns than operations involving small UAS, the unique nature of the proposed operations, including the low-risk rural environments in which the operations will occur, will ensure that safety is not jeopardized. While Part 107 will not apply to the proposed operations, wherever possible, Alpha Drones USA intends to conduct the proposed operations in accordance with Part 107. Moreover, all UAS operations that meet the definition of an “agricultural aircraft operation” will be conducted in accordance with those portions of Part 137 from which Alpha Drones USA is not exempted. In addition to compliance with Part 107 and the applicable sections of Part 137, Alpha Drones USA proposed operations include the following mitigations, however, full SRMs regarding certain elements of the operations are also included:

- Prior to any flight operation, Alpha Drones USA will visit the area of planned operation and inspect the terrain and vantage points. Alpha Drones USA utilizes a number of tools available to capture this environmental data, including high-resolution LiDAR, photogrammetry, and handheld surveying tools. The result is a geo-rectified model of the unit, with GPS points accurately marking the boundaries of the geofenced flight operating area.
- Following that, all state and local paperwork associated with the operation will be filed before and after operations. Alpha Drones USA will comply with all state laws regarding the application of pesticides. These include state and local agency notification, mapping, and specified safety procedures.
- The PIC will hold a Part 107 remote pilot airman certificate and be at least 18 years of age.
- Prior to beginning operations, the PIC will take all preflight actions as set forth in its flight manual, which includes a comprehensive preflight checklist.
- At least one visual observer (VO) will be used for each aircraft during all operations. Both the PIC and VO will maintain a safe distance from the UAS when it is operating as set forth in its flight manual.
- Flights will be limited to a maximum altitude of no more than 200 feet above ground level (AGL) and will normally be flown at average altitudes of 10 to 50 feet AGL or less over private fields and other agricultural areas.
- The areas to be flown are remote agricultural sites or other uninhabited agricultural sites which makes for excellent VLOS conditions.
- All operations will occur in a closed-access environment.
- All personnel at the site will be controlled by Alpha Drones USA at the time of flying. The AGRAS T-16 shall operate from on-site takeoff/landing locations directly next to

the PIC and co-located VO. The PIC and the VO will be able to verbally communicate during all operations or will utilize hand-held radios on site. In addition, signage announcing future spraying operations will be posted at the site entrance warning any customer employees or non-Participants that an aerial spraying operation is occurring. This is an industry standard process.

- The maximum flight time for each UAS flight will be a maximum of 40 minutes, with most agricultural flights lasting approximately 10-20 minutes.

I. Alpha Drones USA Enhanced Pilot Training and Experience Standards

Through its robust training program, which requires aeronautical knowledge, experience, and flight proficiency beyond that required by Part 107, Alpha Drones USA will be able to achieve a level of safety equivalent to what would be obtained using a PIC holding a manned pilot certificate under Part 61.

Alpha Drones USA has integrated safety elements into the operation of its UAS, including comprehensive pilot and VO training and certification requirements that establish an equivalent level of safety to operations conducted with a PIC that holds a manned pilot certificate. These requirements include: a comprehensive UAS training course, which includes theory and practical components, a pilot theory exam, supervised flight training, including agricultural spraying, completion of Alpha Drones USA training and examination program requirements, minimum flight time requirements, demonstrated practical flying ability for the relevant tasks, and continued periodic training after certification.

Aeronautical Knowledge

The following chart addresses each aeronautical knowledge requirement of § 61.125 and explains whether it is relevant to, different from, or addressed by Part 107 operations or Alpha Drones USA internal procedures.

§ 61.125, Aeronautical Knowledge	Alpha Drones USA Operations Under Part 107
(1) Applicable Federal Aviation Regulations of this chapter that relate to commercial pilot privileges, limitations, and flight operations;	Addressed by Part 107
(2) Accident Reporting	Addressed by Part 107
(3) Basic aerodynamics and the principles of flight	Topics applicable to unmanned aircraft are included in Part 107.
(4) Meteorology	Applicable meteorology principles are covered by Part 107.
(5) Safe and Efficient Operation of Aircraft	Covered by Part 107 and included in Alpha Drones USA training. Topics applicable to unmanned aircraft are included in Part 107.
(6) Weight and Balance	“Loading and Performance” is addressed by art 107. Alpha Drones USA will comply with the weight limitations of Part 107 and will ensure that external loads do not negatively impact flight characteristics, as required by Part 107.
(7) Performance Charts	Not directly applicable.

(8) Effects of exceeding aircraft performance limitations	“Loading and Performance” is addressed by art 107. Alpha Drones USA will comply with the weight limitations of Part 107 and will ensure that external loads do not negatively impact flight characteristics, as required by Part 107.
(9) Pilotage and dead reckoning	Not applicable.
(10) Use of air navigation facilities	Topics applicable to unmanned aircraft are included in Part 107.
(11) Decision making and judgment	Covered by Part 10.7
(12) Principles and functions aircraft systems	Covered by Part 107 and by Alpha Drones USA internal procedures and use of operations manuals.
(13) Emergency operations	Covered by Part 107.
(14) Night and high altitude	Not applicable.
(15) Operating within the national airspace system	Covered by Part 107.
(16) Lighter than air ratings	Not Applicable.

Flight Proficiency

FAR § 61.127 contains flight proficiency requirements for specified aircraft categories. Part 107 contains no flight proficiency requirements, however, to ensure adequate flight proficiency, Alpha Drones USA will require demonstrated multi-rotor proficiency in:

- Preflight preparation;
- Preflight procedures;
- Airport and heliport operations;
- Hovering maneuvers;
- Takeoffs, landings, and go-arounds;
- Performance maneuvers;
- Navigation;
- Emergency operations;
- Special operations; and
- Postflight procedures.

Aeronautical Experience

FAR § 61.129 contains requirements for aeronautical experience that are not required for operations conducted under Part 107. To ensure an adequate level of aeronautical experience, Alpha Drones USA will require its pilots to obtain an appropriate level of aeronautical experience, using § 61.129 as a guide, where applicable and reasonable. Many of the requirements § 61.129, however, are either inapplicable or excessive for Alpha Drones USA proposed operations. Commercial helicopter ratings require at least 150 hours of flight time. Much of this, however, need not be in a helicopter or as the PIC. Other flight time requirements in Part 61 are cross-country time or instrument time. There is no need for Part 107 remote pilots to obtain time spent in cross-country flight or instrument flight. Alpha Drones USA pilots will spend all of their time flying the make and model of multi-rotor aircraft that will be used in their operations. These aircraft are far less complicated than manned aircraft. The pilots can, therefore, achieve a comparable level of experience and safety by requiring at least 10 hours of total flight time of a multi-rotor system as the PIC. This will be required by the operations manual and training program.

O. FEDERAL REGISTER SUMMARY

Pursuant to Title 49 U.S.C. § 44807, Special authority for certain unmanned aircraft systems and 14 C.F.R. Part 11, 49 U.S.C. § 44701(f), and 14 C.F.R. Part 11, the following summary is provided for publication in the FEDERAL REGISTER, should it be determined that publication is needed:

Petitioner seeks an exemption from the following rules in Title 14 of the Code of Federal Regulations:

61.3 (a)(1)(i), 91.7(a), 91.119(c), 91.121, 91.151(b), 91.405(a), 91.407(a)(1), 91.409(a)(1) and (2), 91.417(a) and (b), 137.19 (c), (d) and (e)(2)(ii)(iii) and (v), 137.31, 137.33, 137.41(c), 137.42.

Alpha Drones USA requests an exemption for the purpose of operating Unmanned Aircraft Systems (UAS) weighing 55 pounds or more, but no more than and 97.2 pounds to provide commercial agricultural-related services in the United States.

P. CONCLUSION

For the foregoing reasons, Alpha Drones USA respectfully requests that the FAA grant this Petition for Exemption. Should you have any questions, or if you need additional information to support Alpha Drones USA Petition, please do not hesitate to contact the undersigned.